

Strada S5  
The latest parking  
kiosk from Flowbird

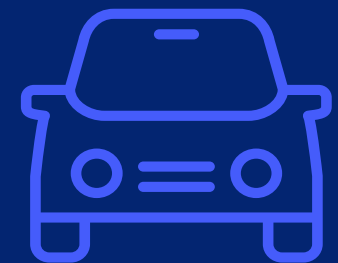

[apararc.com.au](http://apararc.com.au)





## S5 is the ultimate parking kiosk with a friendly touchscreen interface to enhance the user experience

---

Simplified licence plate registration with the 9.7" touch screen – unlike anything in the market

---

Connected to Flowbird's Streetsmart Platform that manages digital tickets, permits, tariffs, and all other kiosk functionality user rights

---

Pay for parking by credit card, and top up stays from your mobile phone

---

Install multiple apps such as advertising, bus timetables, what's on in your city, couponing, and paying for infringements via QR code

---

S5 is the pinnacle of services when it comes to parking/transit and the whole user experience

## New design for higher protection

After 10 years of success all around the world. The legendary design of our well known parking kiosk changes to match the latest parking kiosk directives.

Top Polyamid coverage protection as standard for robustness

Compliant with standards for the disabled

New coating with higher resistance against U.V.

Collection are always protected with lower door

Stainless steel base plate for better protection against scratches on painting during installation. Compatible with existing pedestal.



One upper door to access components for service and maintenance

One lower door to access cash collection and change battery

## New 30W Solar Panel for energy harvesting enhancement

Designed and tested in labs and field test conditions

Heavy usage anticipated – new 4 ways  
rotation 30W solar panel design

### New energy offer

- Standard: 5W + 27Ah battery
- Advanced Plus: 30W + 27Ah battery
- Premium: 30W + 42 Ah battery
- Premium Plus: 30W + 12Ah + 27Ah + 42Ah batteries



# Multiple colour availability

**Sterling Grey**  
NCS4010 R70B



**Anthracite Grey**  
RAL7016



**Moss Green**  
RAL6005



**Magic Bleu**  
RAL 5003



**Titanium Mat**  
Flowbird reference



**Jet Black**  
RAL 9005



# New design features

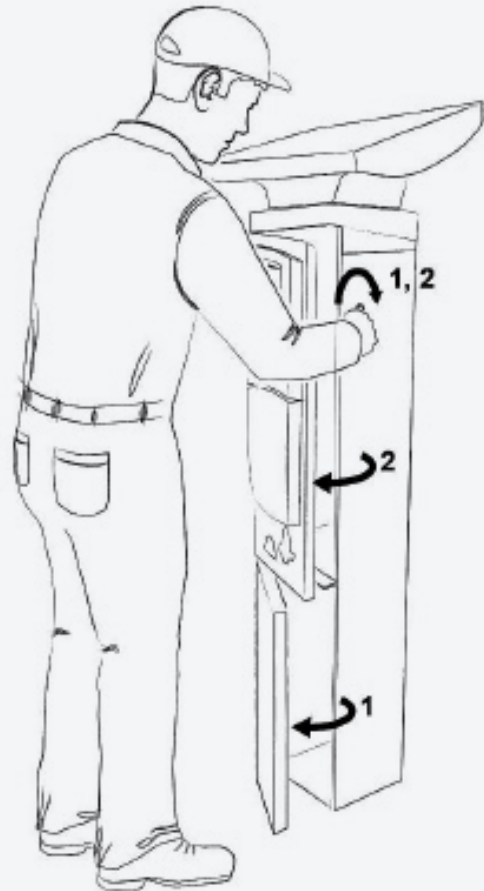

1

## Dual Lock

One mechanical lock with 2 keys to maintain and service kiosk simplifying daily operation

---

KEY 1 opens  
**2 doors simultaneously**

---

KEY 2 opens  
**lower door only**

2

Coloured Zone Indicator available in 5 colours



# New design features



## 3 New catalogue of locks and keys for upper and lower compartments

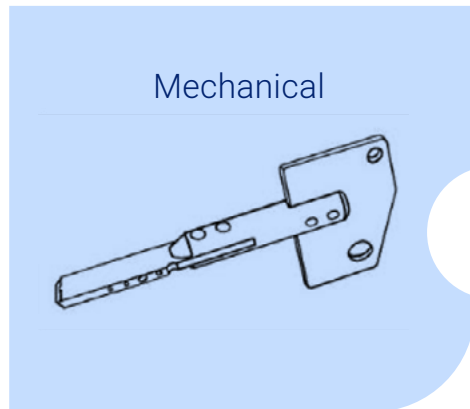

OR

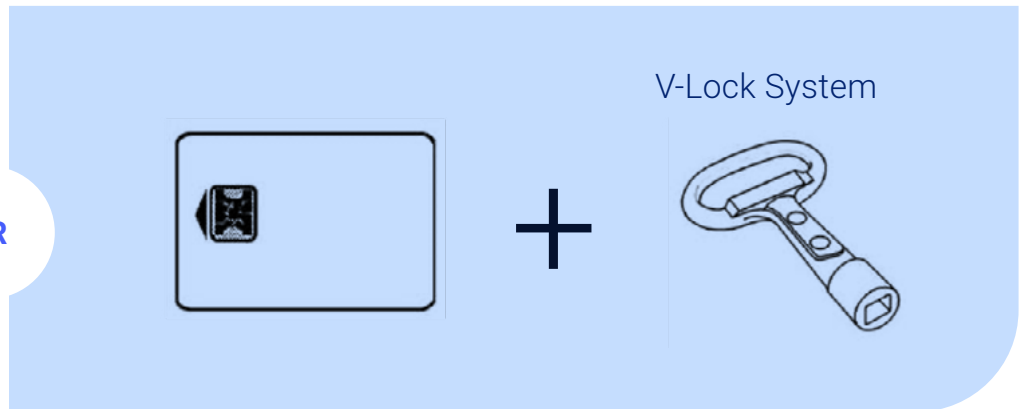

Upper

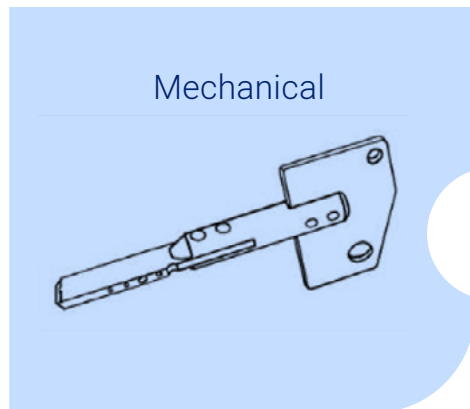

OR

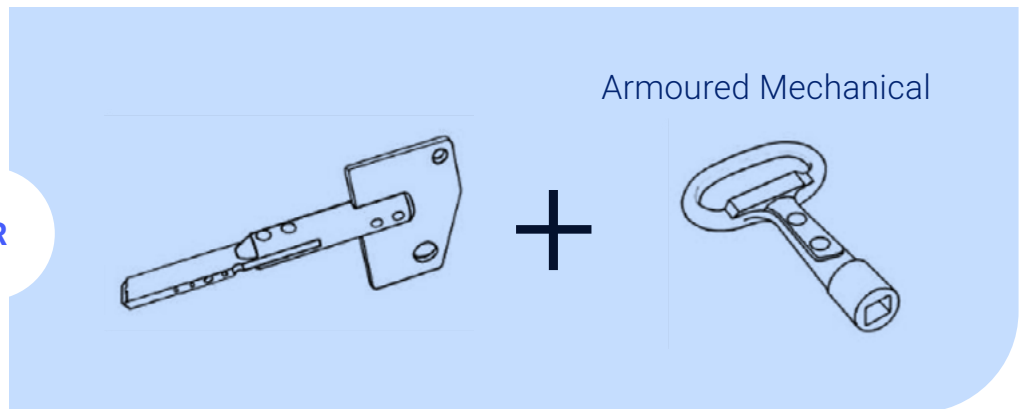

Lower

# User Interface Height

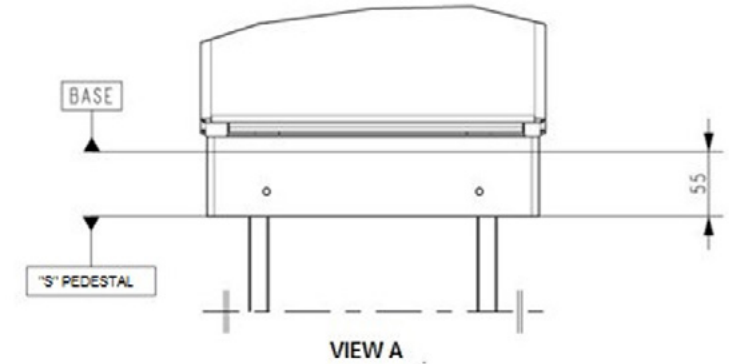
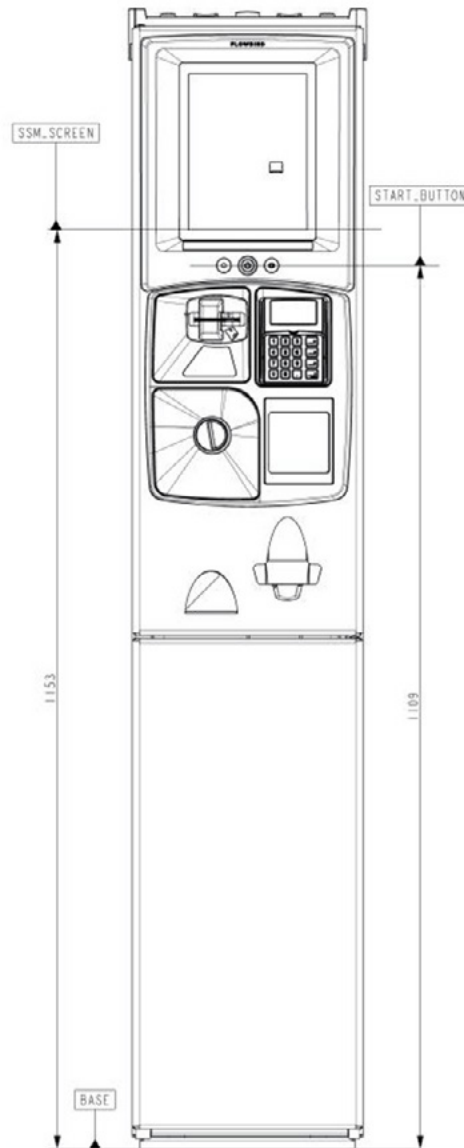

Spacers raise the machine to three different sizes. Heights in mm, round to the nearest mm.

Size	SDA extra height* (mm)	Touch screen (mm)
<b>S</b>	55	1208
<b>M</b>	77	1230
<b>L</b>	143	1296

\* 2mm gap included between Spacer and housing



# Strada Pal and Strada Evolution Technical Specifications



[aparc.com.au](http://aparc.com.au)

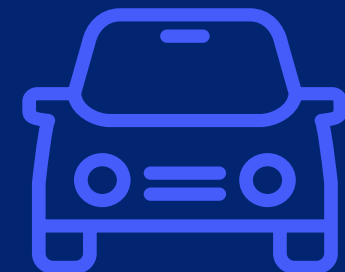

Available in  
five colours

Deployed for more than 15 years, the Strada Parking Kiosk is extremely adaptable to any configuration.

Offers a compact design  
with a friendly interface

Offering remote control and  
maintenance

Based on a structure  
resistant to deterioration and  
fraud integrating a highly  
secure locking system

Combines processing speed,  
power, autonomy, reliability  
and security while supporting  
a wide range of innovations

## Key Features

Upgrade kits such as color screen, communication kit or additional payment means are available in standard. They allow to enhance the user's experience, improve the city's image or enable cities and operators to benefit from the latest parking technologies on existing terminals.

5W or 16.5W solar module or antenna cover provides sufficient performance adapted to each configuration

The instruction panel displays instructions relative to parking such as tariffs

Black and White graphical display enables to get easy instructions on how to pay parking fees

EVO ONLY

The Flowbird's patented coin selector accepts up to 14 different coins and/or tokens

The double-walled cashbox with extra-shieldings is integrated in a separate compartment with high secure system against fraudulent access and degradation attempts

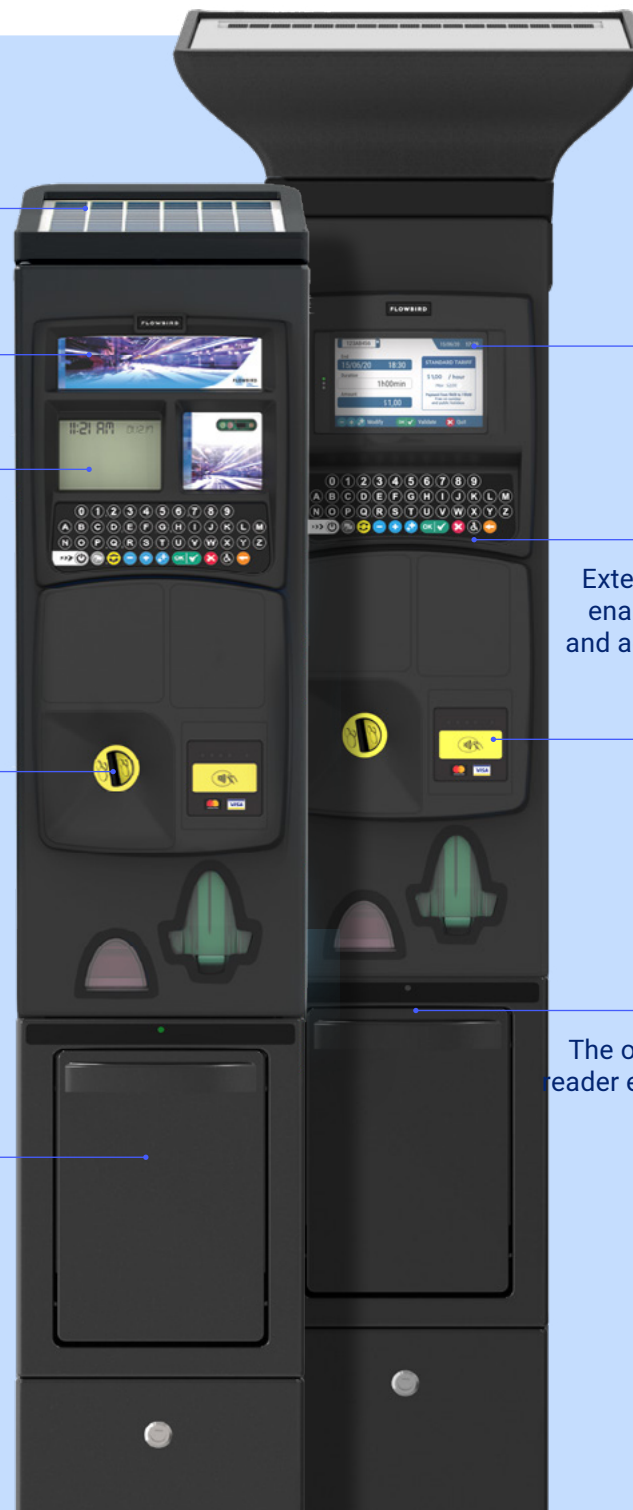

7" color LCD TFT monitor with LED lighting

PAL ONLY

Extended capacitive keyboard enables quick and easy entry, and access to specific services

The modular Contactless card reader A1000, certified PCI PTS V4.x

The optional Barcode/QR Code reader enables to read any 1D-2D code on any support.

## Key Features (cont.)



### Material

Anti-corrosive and anti-graffiti coated steel



### Compliance

EN12414 / CE marking



### Weight

90kg (without batteries and top)



### Capacitive keyboard

3 standard versions (Pay&Display / Pay-by-plate / Pay-by-space)

The Strada Pal is fitted with a large colour screen, a customisable capacitive keyboard and offers both coin, and contactless payment options.

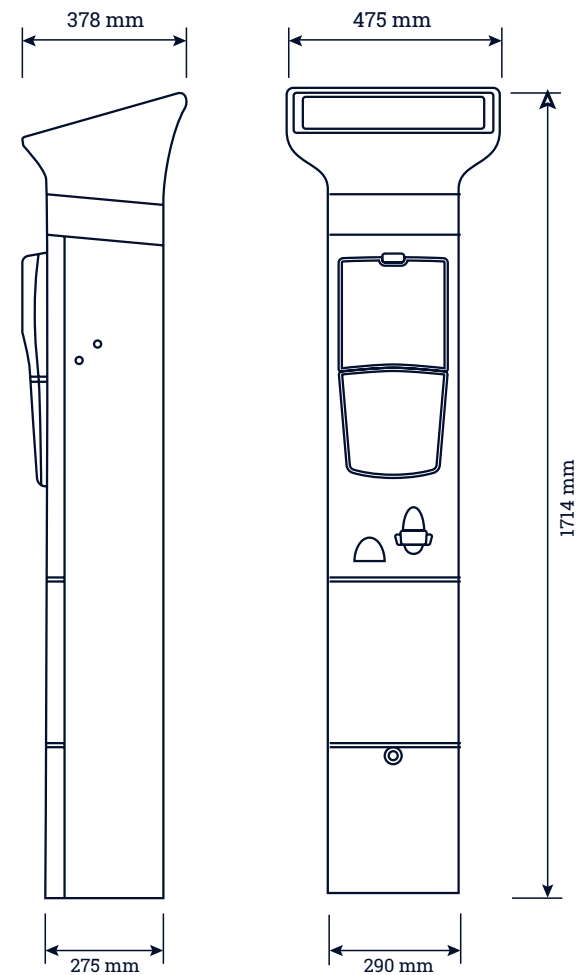

# Specifications

## Payment Options

<b>Coin Selector</b>	<ul style="list-style-type: none"><li>Patented motor-driven coin selector</li><li>Up-to 14 types of coins or tokens accepted</li><li>Automatic opening upon coin insertion</li><li>Multi-criteria coins identification</li></ul>
<b>Contacts &amp; Contactless</b>	<ul style="list-style-type: none"><li>Smartcards &amp; bank cards</li><li>M1000 card reader: PCI PTS 4.x / EMV Level 1 &amp; 2 / AFAS</li><li>P1000 PINPad: PCI PTS 4.x</li><li>A1000 contactless &amp; NFC reader: PCI PTS 4.x / EMV Contactless Level 1 &amp; 2 (Entry point, C2 / Visa, C3/MasterCard, C4 / Amex, C6 / Diners-Discover) / ISO14443 A-B / Mifare</li></ul>
<b>Other</b>	Cashless configuration available

## Collection

<b>Transfer</b>	Fixed cashbox with removable canister: Approx. 1.36kg empty, and 22kg full capacity (around 2800 coins).
<b>Rapide</b>	Exchangeable cashbox: Approx. 1.36kg empty, and 19.50kg full capacity (around 2700 coins)

## Power Supply

<b>Mains</b>	230V
<b>Solar</b>	5W or 16.5W solar panel
<b>Batteries</b>	1 battery 12V-27Ah or 2 batteries 12V-27Ah and 12V-42Ah

## Environment

<b>Recyclability</b>	From 80% to 95% depending on options available (ISO 22628)
<b>European directives</b>	2011/65 RoHS & 2012/19 WEEE

## Tickets

<b>Thermal Graphic Printer</b>	<ul style="list-style-type: none"><li>Horizontal or vertical printing</li><li>Text and logo</li><li>8 dots per mm (203 dots per-inch, per-line) 448 dots per column</li></ul>
<b>Paper or Self Adhesive Ticket</b>	<ul style="list-style-type: none"><li>Without BNA option: 60mm(W) x 70mm(L), capacity of 6500 tickets</li><li>With BNA option: 60mm(W) x 101.6mm(L), capacity of 4500 tickets</li></ul>

## Communication

<b>Modem</b>	3G/4G modem available in certified countries
<b>Connection</b>	Ethernet (mains only)
<b>System</b>	Flowbird NEOPS embedded software

## Security

<b>Money Storage</b>	DTG07131 (EN14450 level 2)
<b>Protection</b>	<ul style="list-style-type: none"><li>Multi-sensors attack detection</li><li>Reinforced locks and additional armourings</li><li>Safety: IP24D &amp; IK9 to IK10</li></ul>

## Miscellaneous

<b>Climatic Pack</b>	Protection of the coin and ticket bowls
<b>Scan</b>	1D-2D QR code reader
<b>Mounting Frame</b>	Compatible with Flowbird and main competitors base anchoring
<b>Anchoring</b>	<ul style="list-style-type: none"><li>Excavation with pedestal</li><li>Flat ground with or without pedestal</li></ul>
<b>Temperature/Humidity</b>	<ul style="list-style-type: none"><li>Operating temperature: -20°C to +55° C (guaranteed during 24 hours)</li><li>Storage temperature: -20°C to +70°C (guaranteed during 16 hours)</li><li>Humidity: up to 95% RH at 55°C</li></ul>



Get the latest Strada  
parking kiosk today.

T 1300 307 441

E [info@aparc.com.au](mailto:info@aparc.com.au)

